

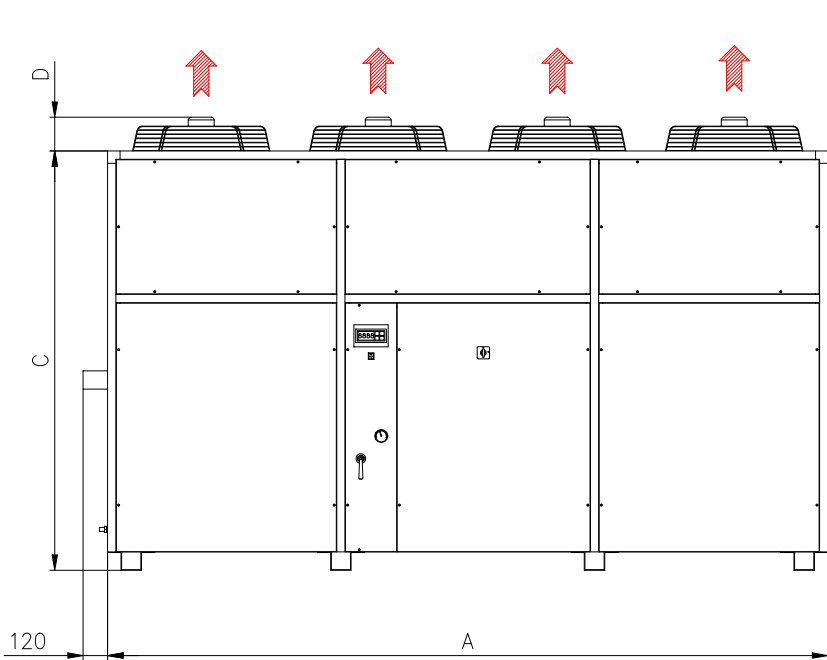

Esquema de dimensiones mod. 501 – 601 – 502 – 602

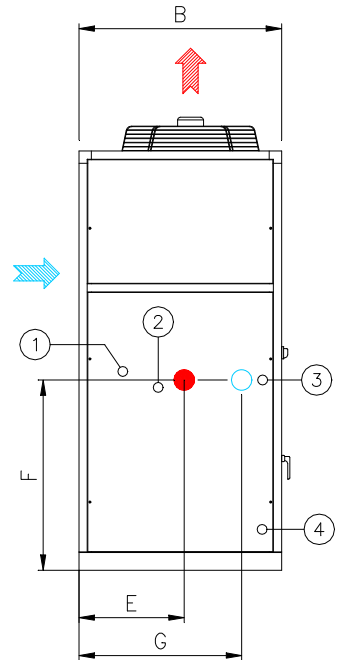

FRONT VIEW



SIDE VIEW

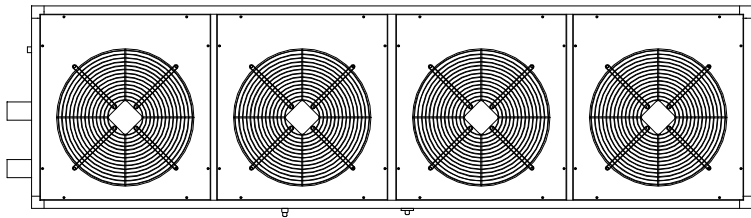

TOP VIEW

- ① CONDENSATE DISCHARGE
- ② AIR PURGE VALVE
- ③ POWER SUPPLY
- ④ WATER DISCHARGE

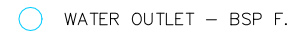
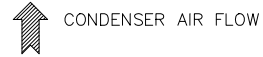

MOD.	A	B	C	D	E	F	G			SHIPPING WEIGHT Kg	OPER. WEIGHT Kg
501	3.520	990	2.050	185	515	930	795	3"	3"	1.600	2.130
601	3.520	990	2.050	185	515	930	795	3"	3"	1.700	2.250
502	3.520	990	2.050	185	515	930	795	3"	3"	1.800	2.350
602	3.520	990	2.050	185	515	930	795	3"	3"	1.900	2.450