

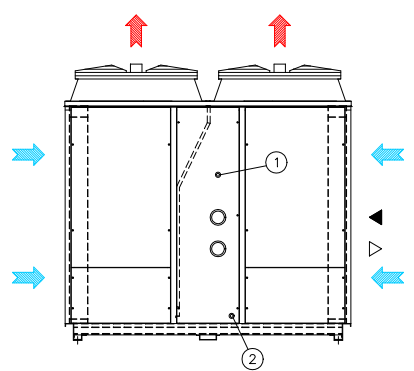

Esquema de dimensiones mod. 1202

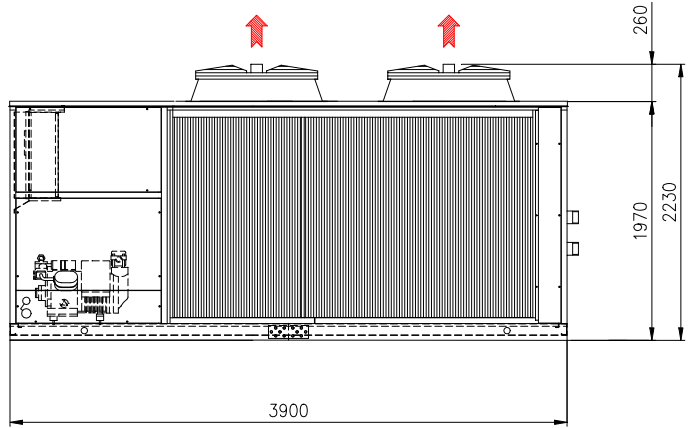

BACK VIEW



SIDE VIEW

- ① AIR PURGE VALVE
- ② WATER DISCHARGE

- CONDENSER AIR FLOW
- WATER INLET DN80 - 3" - BSP M.
- WATER OUTLET DN80 - 3" - BSP M.

