

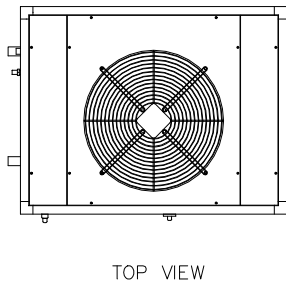

Esquema de dimensiones mod. 81 ÷ 151

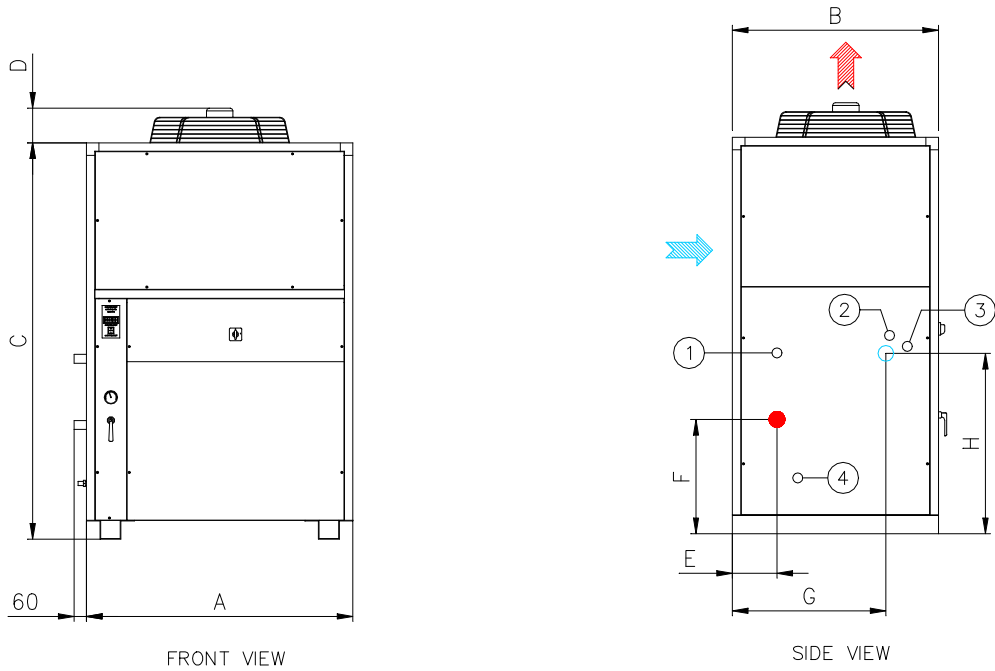

- CONDENSER AIR FLOW
- WATER INLET – BSP F.
- WATER OUTLET – BSP F.
- ① CONDENSATE DISCHARGE
- ② AIR PURGE VALVE
- ③ POWER SUPPLY
- ④ WATER DISCHARGE

MOD.	A	B	C	D	E	F	G	H			SHIPPING WEIGHT Kg	OPER. WEIGHT Kg
81	1280	990	1890	165	205	560	745	540	1" 1/4	1" 1/4	520	680
101	1280	990	1890	165	205	560	745	540	1" 1/4	1" 1/4	550	710
121	1280	990	1890	185	205	560	745	540	1" 1/4	1" 1/4	560	720
151	1280	990	1890	185	205	560	745	540	1" 1/4	1" 1/4	575	740